

## Platinum Resistance Temperature Detector

## MR 828 and 845

MR series elements are designed for applications where high vibration resistance as well as high temperature stability are vital. Typical industrial applications include analytical and medical equipment, chemical plants and mechanical equipment. Small tolerances on diameter allow problem free installation in protective tubes.

Type	Tolerance DIN EN 60751 1996-07	Tolerance DIN EN 60751 2009-05	Order Number	Diameter D in mm
1 Pt 100 MR 828	Class B	F 0.3	32 209 340	2,8 <sup>±0,3</sup>
1 Pt 500 MR 828			32 209 341	2,8 <sup>±0,3</sup>
1 Pt 1000 MR 828			32 209 342	2,8 <sup>±0,3</sup>
2 Pt 100 MR 828			32 209 343	2,8 <sup>±0,3</sup>
1 Pt 100 MR 845			32 209 346	4,5 <sup>±0,3</sup>
1 Pt 500 MR 845			32 209 347	4,5 <sup>±0,3</sup>
1 Pt 1000 MR 845			32 209 348	4,5 <sup>±0,3</sup>
2 Pt 100 MR 845			32 209 349	4,5 <sup>±0,3</sup>
2 Pt 1000 MR 845			32 209 351	4,5 <sup>±0,3</sup>

The measuring point for the basic value is situated at 8 mm from the end of the sensor body

Specification	DIN EN 60751
<b>Nominal resistance</b>	100Ω; 500Ω and 1000Ω at 0°C
<b>Temperature range</b>	-70°C to +500°C (continuous operation) Temporary use to 550°C possible Tolerance Class B: -70°C up to +500°C
<b>Temperature coefficient</b>	TCR = 3850 ppm/K
<b>Leads</b>	Pt clad Ni- wire
<b>Lead lengths (L)</b>	6 mm +2 / -1mm
<b>Longterm stability</b>	max. R <sub>0</sub> -drift 0.1% after 1000h at 500°C
<b>Vibration resistance</b>	according to DIN EN 60751
<b>Environmental conditions</b>	unhoused for dry environments only
<b>Insulation resistance</b>	> 100 MΩ at 20°C; > 2 MΩ at 500°C
<b>Measuring current</b>	100Ω 0.3 to 1.0mA 500Ω 0.1 to 0.7mA 1000Ω 0.1 to 0.3mA (self heating has to be considered)
<b>Response time</b>	Water (v= 0.4m/s) Air (v= 2m/s) MR 828:           t <sub>0,5</sub> = 0.9s   t <sub>0,9</sub> = 2.7s t <sub>0,5</sub> = 12.3s   t <sub>0,9</sub> = 39.5s MR 845:           t <sub>0,5</sub> = 1.5s   t <sub>0,9</sub> = 4.6s t <sub>0,5</sub> = 24.8s   t <sub>0,9</sub> = 78.8s
<b>Self heating</b>	MR 828 (Pt 100/500/1000): 0.05 K/mW at 0°C MR 828 (2 Pt 100/1000): 0.16 K/mW at 0°C MR 845 (Pt 100/500/1000): 0.04 K/mW at 0°C MR 845 (2 Pt 100/1000): 0.08 K/mW at 0°C

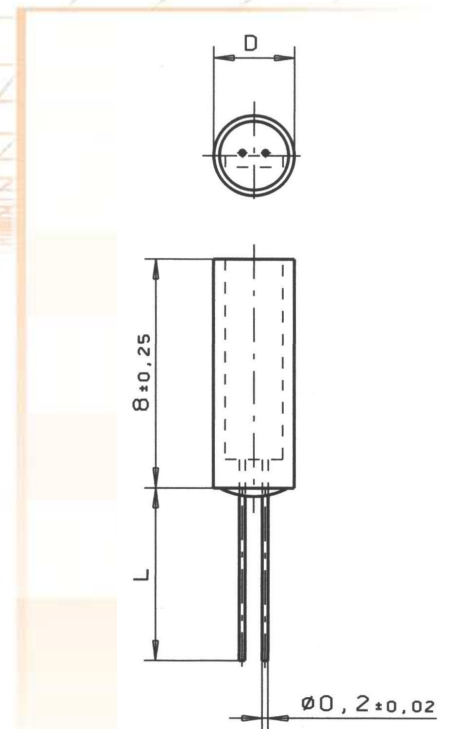

**Packaging** blister reel

**Note** Other tolerances, values of resistance and wire lengths are available on request.

We reserve the right to make alterations and technical data printed. All technical data serves as a guideline and does not guarantee particular properties to any products.

Heraeus Sensor Technology GmbH, Reinhard- Heraeus- Ring 23, 63801 Kleinostheim, Germany  
Phone: +49 (0) 6181/35-8098, Fax: +49 (0)6181/35-8101, E-Mail: [info.HSND@Heraeus.com](mailto:info.HSND@Heraeus.com) Web: [www.heraeus-sensor-technology.com](http://www.heraeus-sensor-technology.com)